



Edition : 1.0
Date: (2/25)

Instruction Manual

PORTABLE MAGNETIC BASE DRILL HF-50

Order Code: (D9508)

MACHINE DETAILS

MACHINE.	MAGNETIC BASE DRILL
MODEL NO.	HF-50
SERIAL NO.	
DATE OF MANF.	

Imported by

AUSTRALIA



www.machineryhouse.com.au

NEW ZEALAND



www.machineryhouse.co.nz

NOTE:

This manual is only for your reference. At the time of the compiling of this manual every effort to be exact with the instructions, specifications, drawings, and photographs of the machine was taken. Owing to the continuous improvement of the HAFCO machine, changes may be made at any time without obligation or notice. Please ensure the local voltage is the same as listed on the specification plate before operating any electric machine.

SAFETY SYMBOLS:

The purpose of safety symbols is to attract your attention to possible hazardous conditions.



WARNING

Indicates a potentially hazardous situation causing injury or death.



CAUTION

Indicates an alert against unsafe practices.

Note:

Used to alert the user to useful information.

NOTE:

In order to see the type and model of the machine, please see the specification plate. Usually found on the back of the machine. See example (Fig.1)

	
PRODUCT SPECIFICATIONS	
Model: HF-50	Voltage: 240V, 50Hz
Capacity: 50mm	Motor: 1.1 KW
Nett Weight: 14 kg	FLC: 4.8 Amps
Date:	
Serial No:	
www.machineryhouse.com.au	www.machineryhouse.co.nz
Made in Taiwan	

FIG.1

CONTENTS:

GENERAL MACHINE INFORMATION	
Specifications.....	4
Included Accessories.....	4
Identification.....	5
IMPORTANT INFORMATION	
General Powertool Safety.....	6
Terminology Used In The Manual.....	7
Drill Safety Warnings.....	8
Magnetic Drill Specific Safety.....	9
Magnetic Base Duty Cycle.....	9
SETUP	
Assembly.....	10
Adjusting The Slide Height.....	10
Mounting The Annular Cutters.....	10
Gear Selection.....	10
2 Speed Chart.....	11
OPERATION	
Operation General.....	11
Twist Drilling.....	12
Gib Adjustment (Dovetail Slides).....	12
MAINTENANCE	
The Arbor Shaft.....	13
Carbon Brushes.....	13
Magnetic Troubleshooting.....	13
Checking The Magnet.....	14
Checking The Rectifier.....	14
Spare Parts.....	15
Risk Assessment Sheets.....	19



CAUTION

A prepared list of safety guidelines can never be complete. Every workshop environment is different. Always consider Safety first, as it applies to your individual working conditions. Use this machine and other machinery with caution and respect. Failure to do so could result in serious Personal injury, damage to the equipment, or poor work results.

SPECIFICATIONS

Order Code	D9508
Model	HF-50
Feed	Manual
Drilling Capacity Range - Manual (mm)	12 ~ 50
Maximum Thickness (mm)	50
Suits Cutter Shank Size (mm)	19
Spindle Stroke (mm)	140
Number of Drilling Speeds	2
Full Load Drilling Speeds (rpm)	180 / 270
No Load Drilling Speeds (rpm)	300 / 450
Magnetic Holding Power (Kg/f)	1733
Motor Power (kW / hp)	1.1 / 1.46
Voltage / Amperage (V / amp)	240 / 10
Machine Weight Only (kg)	14
Nett Weight (kg)	17.5
Machine Weight Only (kg)	24.8
Hard Case	Yes

INCLUDED ACCESSORIES

- Wrench M8
- T-Wrench M6
- L-Hex Key M2.5
- L-Hex Key M4
- Chip Guard kit
- Coolant Tank kit
- Safety Strap

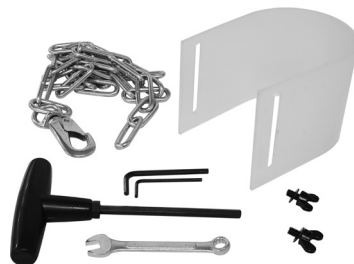

IDENTIFICATION

Become familiar with the names and locations of the controls and features shown below to better understand the instructions when mentioned later in this manual.

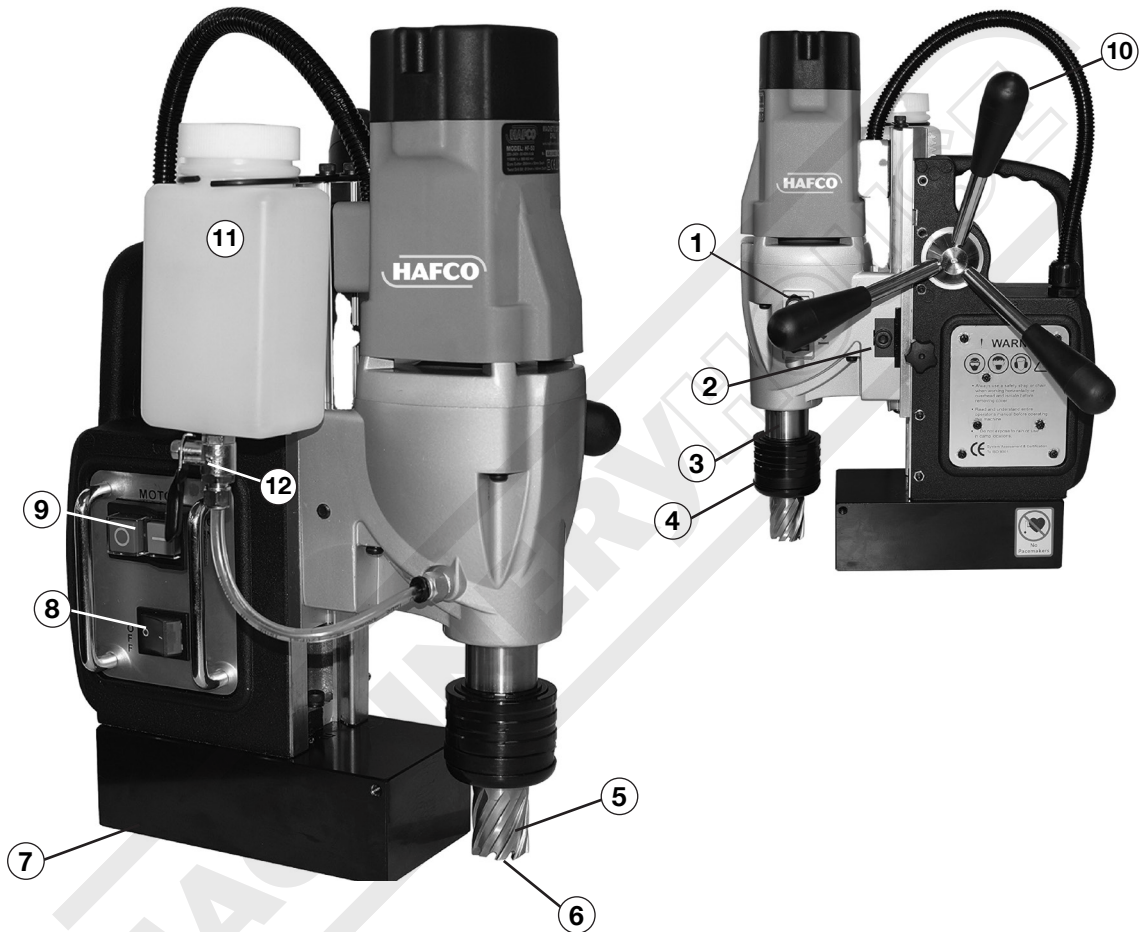

1	Gear Selection	7	Magnetic Base
2	Slide Height Lock	8	Magnet Switch
3	Arbor	9	Motor Switch
4	Quick Release Toolholder	10	Crank Handle
5	Broach Cutter (Not Included)	11	Coolant Tank
6	Pilot Pin (Not Included)	12	Coolant Feed Tap

IMPORTANT INFORMATION

GENERAL POWERTOOL SAFETY



WARNING.

Read and understand the instructions in this manual, before operating this machine to reduce the risk of serious injury or even death. Save all warnings and instructions for future reference

The term “power tool” in the warnings refers to your mains-operated (corded) power tool or battery operated (cordless) power tool.

1) Work area safety

- a. Keep work area clean and well lit. Cluttered or dark areas invite accidents.
- b. Do not operate power tools in explosive atmospheres, such as in the presence of flammable liquids, gases or dust. Power tools create sparks which may ignite the dust or fumes.
- c. Keep children and bystanders away while operating a power tool. Distractions can cause you to lose control.

2) Electrical safety

- a. Power tool plugs must match the outlet. Never modify the plug in any way. Do not use any adapter plugs with earthed (grounded) power tools. Unmodified plugs and matching outlets will reduce risk of electric shock.
- b. Avoid body contact with earthed or grounded surfaces, such as pipes, radiators, ranges and refrigerators. There is an increased risk of electric shock if your body is earthed or grounded.
- c. Do not expose power tools to rain or wet conditions. Water entering a power tool will increase the risk of electric shock.
- d. Do not abuse the cord. Never use the cord for carrying, pulling or unplugging the power tool. Keep cord away from heat, oil, sharp edges or moving parts. Damaged or entangled cords increase the risk of electric shock.
- e. When operating a power tool outdoors, use an extension cord suitable for outdoor use. Use of a cord suitable for outdoor use reduces the risk of electric shock.
- f. If operating a power tool in a damp location is unavoidable, use a residual current device (RCD) protected supply. Use of an RCD reduces the risk of electric shock.

3) Personal safety

- a. Stay alert, watch what you are doing and use common sense when operating a power tool. Do not use a power tool while you are tired or under the influence of drugs, alcohol or medication. A moment of inattention while operating power tools may result in serious personal injury.
- b. Use personal protective equipment. Always wear eye protection. Protective equipment such as a dust mask, non-skid safety shoes, hard hat or hearing protection used for appropriate conditions will reduce personal injuries.
- c. Prevent unintentional starting. Ensure the switch is in the off-position before connecting to power source and/or battery pack, picking up or carrying the tool. Carrying power tools with your finger on the switch or energizing power tools that have the switch on invites accidents.
- d. Remove any adjusting key or wrench before turning the power tool on. A wrench or a key left attached to a rotating part of the power tool may result in personal injury.

GENERAL POWERTOOL SAFETY CONT.

- e. Do not overreach. Keep proper footing and balance at all times. This enables better control of the power tool in unexpected situations.
- f. Dress properly. Do not wear loose clothing or jewelry. Keep your hair and clothing away from moving parts. Loose clothes, jewelry or long hair can be caught in moving parts.
- g. If devices are provided for the connection of dust extraction and collection facilities, ensure these are connected and properly used. The use of dust collection can reduce dust-related hazards.
- h. Do not let familiarity gained from frequent use of tools allow you to become complacent and ignore tool safety principles. A careless action can cause severe injury.

4) Power tool use and care

- a. Do not force the power tool. Use the correct power tool for your application. The correct power tool will do the job better and safer at the rate for which it was designed.
- b. Do not use the power tool if the switch does not turn it on and off. Any power tool that cannot be controlled with the switch is dangerous and must be repaired.
- c. Disconnect the plug from the power source and/or remove the battery pack, if detachable, from the power tool before making any adjustments, changing accessories, or storing power tools. Such preventive safety measures reduce the risk of starting the power tool accidentally.
- d. Store idle power tools out of the reach of children and do not allow persons unfamiliar with the power tool or these instructions to operate the power tool. Power tools are dangerous in the hands of untrained users.
- e. Maintain power tools and accessories. Check for misalignment or binding of moving parts, breakage of parts and any other condition that may affect the power tool's operation. If damaged, have the power tool repaired before use. Many accidents are caused by poorly maintained power tools.
- f. Keep cutting tools sharp and clean. Properly maintained cutting tools with sharp cutting edges are less likely to bind and are easier to control.
- g. Use the power tool, accessories and tool bits etc. in accordance with these instructions, taking into account the working conditions and the work to be performed. Use of the power tool for operations different from those intended could result in a hazardous situation.
- h. Keep handles and grasping surfaces dry, clean and free from oil and grease. Slippery handles and grasping surfaces do not allow for safe handling and control of the tool in unexpected situations.

5) Service

Have your power tool serviced by a qualified repair person using only identical replacement parts. This will ensure that the safety of the power tool is maintained.

TERMINOLOGY USED IN THE MANUAL

- 1. Warning:** This term means that there is a risk of physical harm or death to the operator or people nearby.
- 2. Caution:** This term means that there is a risk of damage to the machine, cutting tool or other equipment.
- 3. Note:** These terms offer useful information relating to the operation of the machine or its maintenance.

TERMINOLOGY USED IN THE MANUAL Cont.

V.....volts

A.....amperes

Hz.....hertz

W.....watt

~.....alternating current

n_0no load speed

min^{-1}revolutions or reciprocation
per minute



.....warning of general danger



.....with electrical earth



.....read these instructions



.....always wear eye protection



.....always wear a dust mask.



.....always wear hearing protection



.....wear safety-approved hard hat



do not dispose of electric tools,
accessories and packaging together
with household waste material

DRILL SAFETY WARNINGS

- The drill must be secured. A drill that is not properly secured may move or tip over and may result in personal injury.
- The workpiece must be clamped or secured to the workpiece support. Do not drill pieces that are too small to be clamped securely. Holding the workpiece by hand during operation may result in personal injury.
- Do not wear gloves. Gloves may be entangled by the rotating parts or chips, leading to personal injury.
- Keep your hands out of the drilling area while the tool is running. Contact with rotating parts or chips may result in personal injury.
- Make sure the accessory is rotating before feeding into the workpiece. Otherwise the accessory may become jammed in the workpiece, causing unexpected movement of the work piece and personal injury.
- When the accessory is jammed, stop applying downward pressure and switch off the tool. Investigate and take corrective actions to eliminate the cause of the jam. Jamming can cause unexpected movement of the workpiece and personal injury.
- Avoid generating long chips by regularly interrupting downward pressure. Sharp metal chips may cause entanglement and personal injuries.
- Never remove chips from the drilling area while the tool is running. To remove chips, move the accessory away from the workpiece, switch off the tool, and wait for the accessory to stop moving. Use tools such as a brush or hook to remove chips. Contact with rotating parts or chips may result in personal injury.
- Accessories with speed ratings must be rated at least equal to the maximum speed marked on the power tool. Accessories running faster than their rated speed can break and fly apart.



WARNING!

People with pacemakers should consult their physician(s) before use. Electromagnetic fields in close proximity to heart pacemaker could cause pacemaker interference or pacemaker failure.

MAGNETIC DRILL SPECIFIC SAFETY

- a. **Always use safety Strap.** Mounting can release.
- b. **WARNING:** While operating, only hold the crank handles, not any other part of the machine. Placing the hand on the machine may result in an electric shock in the event of a voltage leak or if the machine cuts its own power supply cable.
- c. **Always ensure that the work piece is a minimum of 12mm (7/16 in.) thick.** If it is not, then use a piece of steel plate at least 12mm thick and larger than the magnet, below the work piece, to supplement the magnetic adhesion. The magnet's adhesion depends on the thickness of the work piece.
- d. **Do not operate the machine on a workpiece while it is being welded.** This may lead to damage to the machine and/or personal injury.
- e. **Never position machine on a work piece between the electrode and the ground of any arc type welder.** The welder's current will ground through the earth wire in the machine's power supply cable, causing it damage.
- f. **Do not exceed 90 degrees from horizontal.** It is hazardous to use the drill upside-down.
- g. **Always ensure that the magnet is clean and free of rust and scale.** Metal chips and other debris will hamper magnetic adhesion.
- h. **Always use the tool alone on the receptacle.** Other units used on the same receptacle could cause uneven voltage that could lead to the magnet releasing.
- i. **Ensure that the magnet has properly adhered to the work piece before beginning drilling.** Proper magnet adhesion is essential for safe drilling.
- j. **When drilling non-ferrous (non-magnetic) work materials,** only use a manufacturer-approved fixture such as a vacuum base adapter. Use of accessories which are not manufacturer-approved proved could result in a hazardous situation.
- k. **Do not operate with dull or damaged cutting tools.** This may overload the motor.
- l. **Avoid operating annular cutters without cutting fluid.** Always check fluid level before operating. Annular cutters require cutting fluid for proper operation and long life.
- m. **Protect the motor.** Never allow cutting fluid, water, or other contaminants to enter the motor. This could lead to electric shock or motor damage.
- n. **When drilling stacked work materials,** always stop to clear the slug after the first layer is drilled. The loose slug will interfere with proper drilling.
- o. **CAUTION:** Never attempt to use machine with incorrect current or abnormally low voltage. Incorrect voltage could lead to motor damage.
- p. **This machine is not intended for production-line type use.**

MAGNET BASE DUTY CYCLE

Do not leave the magnet base activated continuously for more than 60 minutes. If the magnet base is overheated, allow it to cool for 30 minutes before continuing.

CAUTION: Turn the magnet base off when not in use. Leaving the magnet base on continuously will damage it.



WARNING!

Electricity is dangerous and could cause death

All electrical work must be carried out by a qualified electrician.

3. SET-UP

ASSEMBLY

Coolant tank assembly required. First attach clear tube to the bottom of the coolant tank. To do this, first loosen the nut and slide nut onto the tube. Then slide tube onto the nipple. Then tighten the nut. Slide tank hanger over the screw on the upper right hand side of slide and tighten. Finally insert the other end of the tube into the quick-release connector in the gearbox. Just directly push in to install. (To remove, first firmly push the red collar of the connector and pull the tube out.)

Cutting coolant fluid is always required when using annular cutters. Open the tank cover and fill. Check coolant fluid level often. Keep coolant tap closed when not in use.

Chip guard must be used. To attach the chip guard, use the supplied butterfly bolts to bolt to the magnet. It is not necessary to remove guard to clean chips. Simply raise guard to upper position.

Safety Strap must be used. Loop strap around the workpiece, feed strap through the power tool's handle, and tighten strap using the ratchet mechanism.

ADJUSTING THE SLIDE HEIGHT

Adjustable slide height models allow the operator to quickly change the height position of the motor head on the slide. This is useful when switching between twist drills and annular cutters, for example. For annular cutters, use the lowest position possible for best stability. For twist drills, raise the motor head to allow enough clearance for the twist drill to be mounted.

To adjust:

1. Using the T-handle hex wrench, loosen the socket cap screw on the Slide Height Lock.
2. Slide the motor head to the desired position.
3. Tighten the Slide Height Lock.



MOUNTING ANNULAR CUTTERS

CAUTION: Never use a cutting tool that is larger than the maximum rated capacity of the machine.

Push up on the quick-release collar. Insert the cutter with pilot pin and turn until the flat meets the locking pin. When the flat meets the locking pin, the collar will snap down. Double check to ensure that it is fully locked.

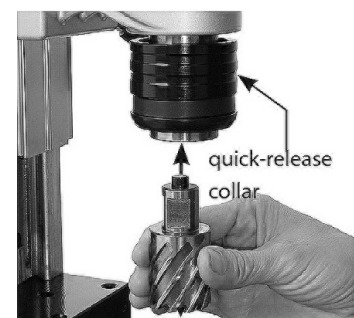

GEAR SELECTION

Before drilling, select the desired gear range by first swinging the gear selector tab out of the detent slot then shifting into the correct gear. Then pop the selector tab back into the detent. It will usually be necessary to turn the spindle by hand a little to get it to shift all the way.

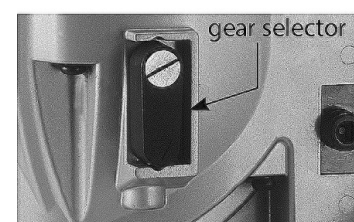

2 SPEED GEAR CHART

Gear	No Load Speed	Full Load Speed	Cutter Size
1	300 mm ¹	180 mm ¹	≤ 50mm (2") HSS Cutters
2	450 mm ¹	270 mm ¹	≤ 50mm (2") TCT Cutters

NOTE: These speeds are general recommendations only. Actual speeds should be determined by the material and the cutting speed recommended by the cutting tool manufacturer. See the section below.

“RECOMMENDED SURFACE SPEEDS” and use the formula to calculate the best RPM.

CAUTION: Ensure that gears engage fully.

CAUTION: ALWAYS ensure that the machine is fully stopped before attempting to change gears! NEVER change gears on a running machine!

OPERATION-GENERAL

WARNING: Always ensure that the magnet is adhered properly to the work piece before beginning drilling.

NOTE: If mounting to a curved surface beam, mount the machine parallel to the curve in the work piece.

WARNING: Avoid operating at more than 90 degrees from horizontal. When drilling at such an angle take precautions to prevent cutting coolant from entering the motor. Paste-type coolant should be used.

1. First fit tool into arbor and line up with intended center of cut. Then switch the magnet on.
2. Press green motor ON button to start motor. Use the crank handle to feed the cutter to the work. Always use very light pressure when beginning the cut and just as the tool is breaking through. The crank handle offers tremendous leverage; so do not use too much force. Allow the cutting tool to determine the pace. With experience, the operator will be able to determine the best pace to feed the cutter to the work. There should be some degree of audible slowing of the motor but not bogging in the cut. Correct cutting speed with a properly sharp annular cutter will produce long unbroken chips, which produce a “bird’s nest” shaped bundle of chips around the cut.

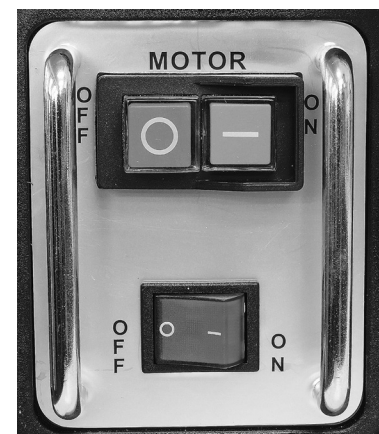

NOTE: Always ensure that the cutting tool is sharp. A dull cutter typically will have finer and or choppy shavings.

WARNING: ALWAYS clear chips when there is too much build-up. Excessive chip build-up could result in a jammed cutter or other hazardous situations.

WARNING: the slug ejects at end of cut and is very hot. Always provide a method of catching the slug, where the ejected slug may cause injury to people below.

Note: Lock the slide lock on the side of the machine in the fully raised position when at rest to prevent the slide from accidentally slamming down - remember to unlock it again before commencing drilling.

CAUTION: Never attempt to cut half-circles or to stitch drill (drill overlapping holes) with a TCT cutter. This may destroy the cutter.

CAUTION: Never attempt to re enter a half-finished cut if the magnet has been turned off and the machine shifted in the interim. This may destroy the cutter.

CAUTION: Do not leave the magnet on for extended periods of time. This will lead to overheating of the coils and subsequent early failure. Only turn the magnet on when you are ready to drill and turn back off when you are done.

TWIST DRILLING

1. First mount the Chuck to the Chuck adaptor.
2. Then push up on the Quick-Release Collar. Insert the Chuck Adaptor into the Tool Holder and turn until the Quick-Release Collar snaps down.
3. Always double check to ensure that the Quick-Release Tool Holder is fully locked.
4. Insert the twist drill into the Chuck and tighten with the chuck key.

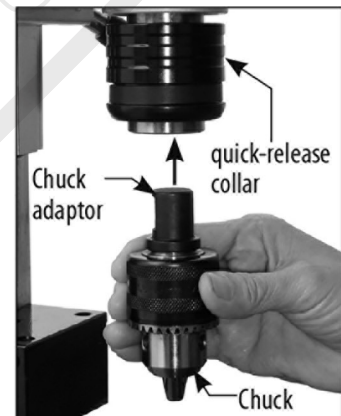

GIB ADJUSTMENT (DOVETAIL SLIDES)

The gibs require adjustment if too loose. To adjust, loosen the lock nuts and adjust the adjuster screws evenly while moving the handle up and down.

Adjust so that there is no free play, without any binding anywhere in its range of travel. Then re-tighten the lock nuts. Periodically check, lubricate, and adjust as needed.



WARNING

Keep hands and fingers away from the cutter. Stop the cutter before opening the hand protection shield. Moving blade cutter hazard may cause serious injury.

MAINTENANCE

Every 50 hours of operation blow compressed air through the motor while running at no load to clean out accumulated dust. (If operating in especially dusty conditions, perform this operation more often.)

1. Keep the machine clean and free of chips.
2. Check for loose fittings and tighten as needed.
3. Ensure that the ventilation slots are clear so that motor can be cooled normally. Blow low-pressure compressed air through the ventilation slots with the motor running to keep motor clean.

THE ARBOR SHAFT

Keep the arbor shaft free of dirt and lightly grease as needed. If the arbor support bearing is noisy, it may be dirty or have a chip lodged in it. Remove the arbor shaft to clean and re-grease the arbor support bearing.

THE CARBON BRUSHES

The carbon brushes are a normal wearing part and must be replaced when they reach their wear limit.

Caution: Always replace the brushes as a pair.

To replace

1. Remove the 4 screws and remove the motor tail cover.
2. Using pliers rotate the brush spring out of the way and slide the old carbon brush out of the brush holder.
3. Unscrew the screw to remove the brush lead. The old carbon brush may now be lifted away.
4. Install a new brush. Installation is the reverse of removal.
5. Replace the motor tail cover.

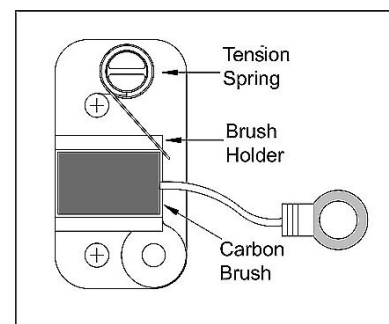
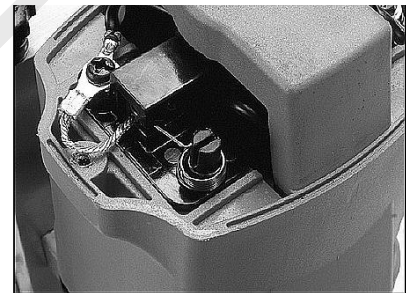

CARBON BRUSHES

Due to the brush design, if the machine comes to a stop without any reason, the brushes have to be checked. The brush design stops the machine before the carbon brushes are finished and protects the motor.

MAGNET TROUBLESHOOTING

Full magnet performance is absolutely essential for magnetic drill operation.

If the magnet works, but does not hold well, it is likely that one of the coils has failed. If the magnet does not work at all, it is likely to be a failed rectifier. (It is highly unlikely that both magnet coils would fail at the same time)

NOTE: A faulty magnet coil can also damage the rectifier, so whenever there is a magnet problem, BOTH the magnet coils and rectifier must be checked.

WARNING: Never attempt to operate a magnetic drill with a faulty magnet!

CHECKING THE MAGNET (qualified technicians only)

If the magnet is not working well, it must be checked. Separate the wires of each individual coil and test the resistance of each coil separately. (note that 110V models are wired in parallel and 230V models are wired in series).

The resistance of the coils of different sizes of magnets varies, but it should be in the region of hundreds of ohms. Most importantly, both coils must have very nearly the same resistance. If one of the coils has zero resistance, it means that it is shorted. If one of the coils has infinite resistance, it means that the circuit is broken.

If either coil has a problem, the magnet must be replaced. A faulty magnet may also cause damage to the rectifier. Also check the rectifier when replacing a faulty magnet. (see below)

CHECKING THE RECTIFIER (Qualified technicians only)

The rectifier takes the AC household current and converts it to DC to power the magnet. If it fails, the magnet coils will not receive power.

Disconnect the rectifier and test the resistance of both circuits of the rectifier between the AC and the DC sides.

Note that polarity matters, so you can only take a reading if test probes are oriented correctly. Each side will be the opposite of the other. Both circuits should have very nearly the same resistance reading. If one of the circuits has zero resistance, it means that it is shorted. If one of the circuits has infinite resistance, it means that the circuit is broken.

If the replacement of the power supply cord is necessary, this has to be done by the manufacturer or their agent in order to avoid a safety hazard.

WARNING: All repairs must be entrusted to an authorized service center. Incorrectly performed repairs could lead to injury or death.



CAUTION

Before attempting this feature, disconnect the machine from the power supply to avoid injury to the operator from accidental startup, injury or death to the operator.

MAGNETIC BASE DRILL

HF-50

ORDER CODE: (D9508)

EDITION : 1.0
DATE: (02/25)

The following section covers the spare parts diagrams and lists that were current at the time this manual was originally printed. Due to continuous improvements of the machine, changes may be made at anytime without notification.

HOW TO ORDER SPARE PARTS

1. Have your machines model number, serial number & date of manufacture on hand, these can be found on the specification plate mounted on the machine.
2. A scanned copy of your parts list/diagram with required spare part/s identified.

NOTE: SOME PARTS MAY ONLY BE AVAILABLE AS AN ASSEMBLY

3. Go to www.machineryhouse.com.au/contactus and fill out the inquiry form attaching a copy of scanned parts list.

**WARNING!**

*Electricity is dangerous and could cause death.
All electrical work must be carried out by a qualified electrician.*

**CAUTION!**

It is impossible to cover all possible hazards Every workshop environment is different. These are designed as a guide to be used to compliment training and as a reminder to users prior to equipment use. Always consider safety first, as it applies to the individual working conditions.

SPARE PARTS DIAGRAM (HF-50)

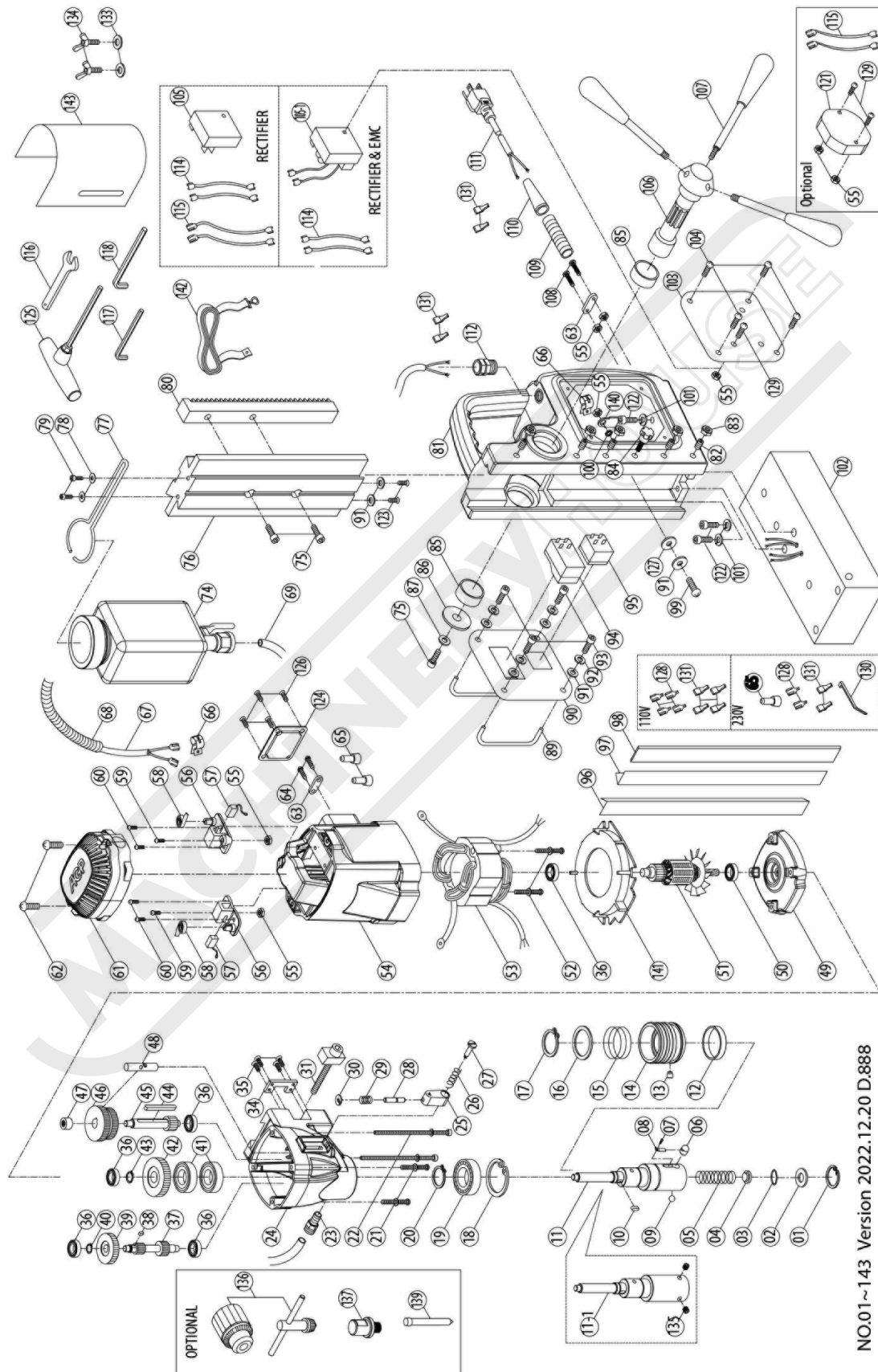

NO.01~143 Version 2022.12.20 D.888

SPARE PARTS LIST

Item	Description	Qty	Item	Description	Qty.
1	INTERNAL CIRCLIP (R-19)	1	57	CARBON BRUSH (7x11x17)	2
2	FLAT WASHER (Ø10xØ18.5x0.8)	1	58	BRUSH SPRING (0.35x3x3T)	2
3	O-RING (Ø12x4)	1	59	PANHEAD MACHINE SCREW (M4x10xP0.7)	2
4	WATER SEAL (Ø12x15)	1	60	PANHEAD TAPPING SCREW (M4x12)	4
5	SPRING (Ø1.2xØ10.1xØ12.5x12Tx85L)	1	61	MOTOR TAIL CASTING	1
6	LOCK PIN (12.3MM)/(11.7MM)	1	62	PANHEAD TAPPING SCREW (M4x25)	2
7	PANHEAD MACHINE SCREW (M3x4xP0.5)	1	63	CABLE CLIP	2
8	LOCK PIN SPRING	1	64	PANHEAD TAPPING SCREW (M4x14)	2
9	CHECK BALL (Ø8)	1	65	CRIMP CAP CONNECTOR (C4)	3
10	PARALLEL KEY (5x5x10)	1	66	CABLE CLAMP	2
11	SPINDLE (194.5MM)	1	67	WIRE (1.25x2Cx65CM-VCTF)	1
11-1	SPINDLE	1	68	CABLE PROTECTOR (5/16"x40CM)	1
12	RING (Ø40xØ44x9)	1	69	TUBE (Ø4xØ6x20CM)	1
13	COLLAR PIN (Ø8)	1	74	COOLANT TANK ASSEMBLY	1
14	QUICK-RELEASE COLLAR	1	75	SOCKET CAP SCREW (M6x16xP1.0)	3
15	SPRING (Ø2.3xØ39xØ43.6x3Tx30L)	1	76	SLIDE PLATE (L217MM)	1
16	SPRING SEAT RING (Ø35.1xØ44.5x2)	1	77	COOLANT TANK BRACKET	1
17	EXTERNAL CIRCLIP (S-35)	1	78	FLAT WASHER (Ø5xØ12x1)	2
18	INTERNAL CIRCLIP (R-47)	1	79	SOCKET CAP SCREW (M5x16xP0.8)	2
19	BALL BEARING (6005)	1	80	GEAR RACK (M1.5x150L)	1
20	EXTERNAL CIRCLIP (S-25)	1	81	STAND BODY	1
21	PANHEAD TAPPING SCREW (M5x65)	2	82	SOCKET SET SCREW (M5x20xP0.8)	5
22	PANHEAD TAPPING SCREW (M5x110)	2	83	HEX NUT (M5xP0.8)	5
23	PUSH LOCK FITTING (PT1/8"xØ6)	1	84	THUMB SCREW (M5x16)	1
24	GEAR HOUSING	1	85	BUSHING (Ø28xØ32x12)	2
25	SELECTOR TAB	1	86	FLAT WASHER (Ø6xØ40x2.5)	1
26	SPRING (Ø1xØ9xØ11x11Lx4T)	1	87	FLAT WASHER (Ø6xØ25x1)	1
27	SHOULDER SCREW	1	89	SWITCH GUARD BAR (90MM)	2
28	DETENT PIN (Ø5x22)	1	90	SWITCH PANEL (90x110x1.5T)	1
29	SPRING (Ø0.6xØ5.3xØ6.5x17Lx5T)	1	91	FLAT WASHER (Ø4xØ10x1)	7
30	E-CLIP (E-3)	1	92	SPRING WASHER (M4)	4
31	SLIDE HEIGHT LOCK	1	93	SOCKET CAP SCREW (M4x16xP0.7)	4
34	LOCK BRACKET	1	94	MOTOR SWITCH (110V/220V)	1
35	FLAT HEAD MACHINE SCREW (M4x10xP0.7)	4	95	MAGNET SWITCH (110V&220V)	1
36	BALL BEARING (608)	5	96	GIB STRIP-LEFT (258MM)	1
37	INPUT SHAFT (M1.0x12Tx17T)	1	97	GIB STRIP-RIGHT (258MM)	1
38	PARALLEL KEY (4x4x8)	1	98	GIB TENSIONER (258x11x1.2T)	1
39	INPUT GEAR (M1.0x36T)	1	99	PANHEAD MACHINE SCREW (M4x16xP0.7)	1
40	EXTERNAL CIRCLIP (S10)	1	100	EXTERNAL STAR WASHER (M5)	1
41	OIL SEAL (Ø25xØ40x7)	2	101	SPRING WASHER (M6)	3
42	OUTPUT GEAR (M1.25x37T)	1	102	ELECTROMAGNET (164x80x48)	1
43	EXTERNAL CIRCLIP (S-15)	1	103	SIDE PANEL (110x90x1.5T)	1
44	PARALLEL KEY (5x5x50)	1	104	PANHEAD MACHINE SCREW (M4x8xP0.7)	4
45	COUNTERSHAFT (M1.25x12T)	1	105	RECTIFIER (110&220V)	1
46	LAY GEAR (M1.0x45Tx40T)	1	105-1	RECTIFIER & EMC (110V)/(110V&220V)	1
47	NEEDLE BEARING (HK 0810)	1	106	CRANK SPINDLE (Ø28)	1
48	SELECTOR FORK (Ø10x50 / Ø4.8x26)	1	107	CRANK HANDLE	3
49	GEAR PLATE	1	108	PANHEAD MACHINE SCREW (M4x30xP0.7)	2
50	BALL BEARING (6001)	1	109	CABLE PROTECTOR (5/16"x7CM)	1
51	ARMATURE (110V/220V-73x42x45)	1	110	CORD ARMOR	1
52	PANHEAD TAPPING SCREW (M5x60)	2	111	POWER SUPPLY CABLE	1
53	STATOR (110V/220V-73x42x45)	1	112	CABLE GLAND (5/16")	1
54	MOTOR HOUSING	1	114	WIRE LEAD (1015-16#18CM)	2
55	HEX NUT (M4xP0.7)	8	115	WIRE LEAD (1015-16#18CM)	4
56	CARBON BRUSH HOLDER (7x11)	2	116	COMBINATION WRENCH (M8)	1

SPARE PARTS LIST

Item	Description	Qty	Item	Description	Qty.
117	HEX KEY (M2.5)	1	133	FLAT WASHER (Ø6xØ13x1)	2
118	HEX KEY (M4)	1	134	BUTTERFLY SCREW (M6x10xP1.0)	2
121	OVER LOAD PROTECTION (110V/220V)	1	135	SOCKET SET SCREW (M8x7xP1.25)	2
122	SOCKET CAP SCREW (M6x20xP1.0)	3	136	CHUCK (1/2")	1
123	TRUSS HEAD MACHINE SCREW (M4x6xP0.7)	2	137	QUICK-RELEASE CHUCK ADAPTORS (1/2')	1
124	MOTOR COVER PLATE	1	139	PILOT PIN (HSSx77LxØ6.34)/(HSSx103LxØ6.34)	1
125	T-HANDLE HEX KEY (M6)	1	139	PILOT PIN (TCTx90LxØ7.98)/(TCTx90LxØ6.34)	1
126	FLAT HEAD TAPPING SCREW (M4x8)	4	139	PILOT PIN (TCTx106LxØ6.34)/(TCTx108LxØ7.98)	1
127	RUBBER WASHER (Ø4xØ11x1)	1	140	EARTHING MARKING	1
128	FEMALE SPADE TERMINAL	4	141	FAN SHROUD	1
129	PANHEAD MACHINE SCREW (M4x25xP0.7)	3	142	SAFETY BELT	1
130	ZIP TIE (2.4x80MM)	1	143	CHIP GUARD	1
131	SPADE TERMINAL BOOT	8			

NOTE: SOME INDIVIDUAL PARTS MAY ONLY BE AVAILABLE AS AN ASSEMBLY

ELECTRICAL

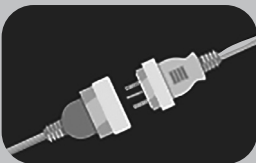
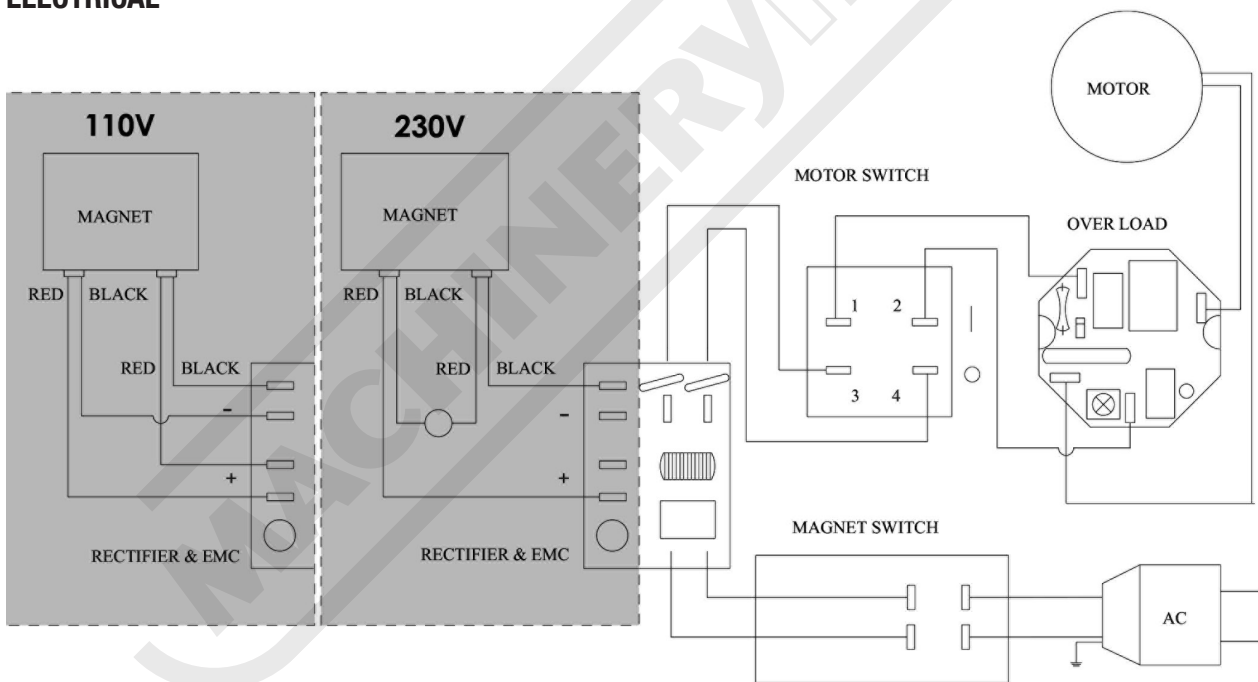

WARNING!

Always disconnect the power to the machine before servicing or doing maintenance to the machine.

WARNING

General Machinery Safety Instructions

Machinery House
requires you to read this entire Manual before using this machine.

- 1. Read the entire Manual before starting machinery.** Machinery may cause serious injury if not correctly used.
- 2. Always use correct hearing protection when operating machinery.** Machinery noise may cause permanent hearing damage.
- 3. Machinery must never be used when tired, or under the influence of drugs or alcohol.** When running machinery you must be alert at all times.
- 4. Wear correct Clothing.** At all times remove all loose clothing, necklaces, rings, jewelry, etc. Long hair must be contained in a hair net. Non-slip protective footwear must be worn.
- 5. Always wear correct respirators around fumes or dust when operating machinery.** Machinery fumes & dust can cause serious respiratory illness. Dust extractors must be used where applicable.
- 6. Always wear correct safety glasses.** When machining you must use the correct eye protection to prevent injuring your eyes.
- 7. Keep work clean and make sure you have good lighting.** Cluttered and dark shadows may cause accidents.
- 8. Personnel must be properly trained or well supervised when operating machinery.** Make sure you have clear and safe understanding of the machine you are operating.
- 9. Keep children and visitors away.** Make sure children and visitors are at a safe distance for you work area.
- 10. Keep your workshop childproof.** Use padlocks, Turn off master power switches and remove start switch keys.
- 11. Never leave machine unattended.** Turn power off and wait till machine has come to a complete stop before leaving the machine unattended.
- 12. Make a safe working environment.** Do not use machine in a damp, wet area, or where flammable or noxious fumes may exist.
- 13. Disconnect main power before service machine.** Make sure power switch is in the off position before re-connecting.
- 14. Use correct amperage extension cords.** Undersized extension cords overheat and lose power. Replace extension cords if they become damaged.
- 15. Keep machine well maintained.** Keep blades sharp and clean for best and safest performance. Follow instructions when lubricating and changing accessories.
- 16. Keep machine well guarded.** Make sure guards on machine are in place and are all working correctly.
- 17. Do not overreach.** Keep proper footing and balance at all times.
- 18. Secure workpiece.** Use clamps or a vice to hold the workpiece where practical. Keeping the workpiece secure will free up your hand to operate the machine and will protect hand from injury.
- 19. Check machine over before operating.** Check machine for damaged parts, loose bolts, Keys and wrenches left on machine and any other conditions that may effect the machines operation. Repair and replace damaged parts.
- 20. Use recommended accessories.** Refer to instruction manual or ask correct service officer when using accessories. The use of improper accessories may cause the risk of injury.
- 21. Do not force machinery.** Work at the speed and capacity at which the machine or accessory was designed.
- 22. Use correct lifting practice.** Always use the correct lifting methods when using machinery. Incorrect lifting methods can cause serious injury.
- 23. Lock mobile bases.** Make sure any mobile bases are locked before using machine.
- 24. Allergic reactions.** Certain metal shavings and cutting fluids may cause an allergic reaction in people and animals, especially when cutting as the fumes can be inhaled. Make sure you know what type of metal and cutting fluid you will be exposed to and how to avoid contamination.
- 25. Call for help.** If at any time you experience difficulties, stop the machine and call you nearest branch service department for help.

WARNING

Magnetic Drilling Machine Safety Instructions

Machinery House
requires you to read this entire Manual before using this machine.

- 1. Maintenance.** Make sure the Magnetic Drill is turned off and disconnect from the main power supply and make sure all moving parts have come to a complete stop before any inspection, adjustment or maintenance is carried out.
- 2. Magnetic Drill Condition.** Magnetic Drill must be maintained for a proper working condition. Never operate a Magnetic Drill that has damaged or worn parts. Scheduled routine maintenance should be performed on a scheduled basis.
- 3. Leaving a Magnetic Drill Unattended.** Always turn the Magnetic Drill off and make sure all moving parts have come to a complete stop before leaving the Magnetic Drill. Do not leave a Magnetic Drill running unattended for any reason.
- 4. Avoiding Entanglement.** Remove loose clothing, belts, or jewelry items. Tie up long hair and use the correct hair nets to avoid any entanglement with the Magnetic Drill spindle or moving parts.
- 5. Chuck key & wrench safety.** Always remove chuck keys, wrenches and any service tools immediately after use. Chuck keys left in the chuck can cause serious injury.
- 6. Understand the machines controls.** Make sure you understand the use and operation of all controls.
- 7. Magnetic Drill bit selection.** Always use the correct Drill bit for the job you are Drilling.
- 8. Secure the Drill Bit.** Make sure the drill bit is inserted correctly into the chuck before operation.
- 9. Cutting Tool inspection.** Inspect Drill for sharpness, chips, or cracks before use. Replace any cutting tools immediately if dull, chipped or cracked. Handle new cutting tools with care. Cutting edges are very sharp and can cause lacerations.
- 10. Reversing the spindle.** Make sure the spindle has come to a complete stop before changing the direction of the spindle.
- 11. Stopping the spindle.** Do not slow or stop the spindle by using your hand.
- 12. Speed selection.** Select the appropriate speed for the type of work, material, and tool bit. Allow the Drill to reach full speed before beginning a cut.
- 13. Clearing chips.** Always use a brush to clear chips. Never clear chips when the drill is running.
- 14. Power outage.** In the event of a power failure during use of the drill, turn off all switches to avoid possible sudden start up once power is restored.
- 15. Clean work area.** Keep the area around the drill clean from oil, tools, chips.
- 16. Surface/Magnetic Clamping.** Before clamping the drill, make sure the surface is clear of any objects (tools, scraps, off-cuts etc.) Do not clamp the drill to a surface that does not have a flat surface.
- 17. Guarding.** All Magnetic drill guards should be in place before any operation.
- 18. Eye and hand protection.** A face shield with safety glasses is recommended. Always keep hands and fingers away from the drill bit. Never hold a workpiece in your hand while drilling.
- 19. Drill operation.** Never start the drill with the drill bit pressed against the workpiece. Feed the drill evenly into the workpiece. Back the drill out of deep holes. Turn the machine off and clear chips and scrap pieces with a brush.
- 21. Pacemaker Protection.** Please note: no person with a pacemaker should be closer than 6 foot or 1.828 metres to an Electromagnetic machine or anything that has an electrical field.
 1. Strong electromagnetic fields can cause electromagnetic interference.
 2. EMI can stop the pacemaker from sensing your heart's rhythm.
- 20. Call for help.** If at any time you experience difficulties, stop the machine and call your nearest branch service department for help.



PLANT SAFETY PROGRAM

NEW MACHINERY HAZARD IDENTIFICATION, ASSESSMENT & CONTROL

Magnetic Drilling Machine

Developed in Co-operation Between A.W.I.S.A and Australia Chamber of Manufactures
This program is based upon the Safe Work Australia, Code of Practice - Managing Risks of Plant in the Workplace (WHSA 2011 No10)



Item No.	Hazard Identification	Hazard Assessment	Risk Control Strategies (Recommended for Purchase / Buyer / User)
A	ENTANGLEMENT	HIGH	Eliminate, avoid loose clothing / Long hair etc.
B	CRUSHING	LOW	Secure Magnetic Drill to workpiece. Keep hands clear of Magnets when clamping.
C	CUTTING, STABBING, PUNCTURING.	MEDIUM	Isolate power to machine prior to any checks or maintenance being carried out. Do not adjust or clean until the machine has fully stopped.
D	SHEARING	MEDIUM	Isolate power to machine when changing speeds or maintenance is being carried out. Make sure all guards are secured shut when machine is on.
F	STRIKING	MEDIUM	Ensure workpieces are tightly secured on machine. Wear safety glasses. Ensure correct spindle direction when drilling.
H	ELECTRICAL	MEDIUM	Electrical enclosures should only be opened with a tool that is not kept with the machine. Never clean or dust machine when power is on.
M	HIGH TEMPERATURE	LOW	Wear appropriate protective clothing to prevent hot swarf.
O	OTHER HAZARDS, NOISE.	LOW	Wear hearing protection as required. Pacemaker Protection. Please note: no person with a pacemaker should be closer than 6 foot or 1.828 metres to an Electromagnetic drill or anything that has an electrical field. 1. Strong electromagnetic fields can cause electromagnetic interference. 2. EMI can stop the pacemaker from sensing your heart's rhythm.
Plant Safety Program to be read in conjunction with manufactures instructions			



www.machineryhouse.com.au



www.machineryhouse.co.nz

Authorised and signed by: 
Safety officer:
Manager: 

Revised Date: 8th July 2014



ENVIRONMENT PROTECTION

Recycle unwanted materials instead of disposing of them as waste. All tools, accessories and packaging should be sorted, taken to a recycling centre and disposed of in a manner which is compatible with the environment. When the product becomes completely unserviceable and requires disposal, drain any fluids (if applicable) into approved containers and dispose of the product and fluids according to local regulations.

IMPORTED BY

HARE & FORBES
MACHINERYHOUSE

Australian Distributor

Hare & Forbes
Machineryhouse
Sydney - Melbourne
Adelaide - Brisbane - Perth

Ph: 1300 202 200
www.machineryhouse.com.au

MACHINERYHOUSE

New Zealand Distributor

Machineryhouse
Auckland
Christchurch

Ph: 0800 142 326
www.machineryhouse.co.nz